

## Modular Cooking Range Line EVO900 4-Burner Gas Range 6kW on Gas Oven

ITEM # \_\_\_\_\_

MODEL # \_\_\_\_\_

NAME # \_\_\_\_\_

SIS # \_\_\_\_\_

AIA # \_\_\_\_\_



392004 (Z9GCGH4SGL)

4-burner (6 kW each) gas  
range on gas oven (8,5 kW)

### Short Form Specification

#### Item No.

To be installed on stainless steel feet with height adjustment up to 50 mm. High efficiency flower flame burners with continuous power regulation and optimized combustion. Flame failure device as standard on burners to protect against accidental extinguishing. Oven chamber with 3 levels of runners to accommodate 2/1 GN shelves (2 steam pans). Ribbed, cast-iron oven base plate. Exterior panels of unit in stainless steel with Scotch Brite finish. Pan supports in heavy duty stainless steel. Extra strength work top in heavy duty 2 mm stainless steel. Right-angled side edges to allow flush-fitting junction between units.

### Main Features

- Unit to be mounted on stainless steel feet with height adjustment up to 50 mm. Unit can be easily mounted on cantilever systems.
- The four 6 kW high efficiency burners are available in 60 mm diameter with continuous power regulation from 1,5 to 6 kW.
- Gas appliance supplied for use with natural or LPG gas, conversion jets supplied as standard.
- Large sized pan support in cast iron (stainless steel as option) with long center fins to allow the use of the largest down to the smallest pans.
- Burners with optimized combustion.
- Flame failure device on each burner protects against gas leakage when accidental extinguishing of the flame occurs.
- Protected pilot light.
- Base compartment consists of a gas heated standard oven with stainless steel burners and self stabilizing flame positioned beneath the base plate. Oven chamber to have 3 levels of runners to accommodate 2/1 GN shelves (2 steam pans) and ribbed cast iron base plate.
- Oven thermostat adjustable from 120 °C to 280 °C.
- 40 mm thick oven door for heat insulation.
- The special design of the control knob system guarantees against water infiltration.
- IPX5 water protection.
- Control knobs provide smooth, continuous rotation from min to max power level.

### Construction

- All exterior panels in Stainless Steel with Scotch Brite finishing.
- AISI 304 stainless steel worktop, 2mm thick.
- Model has right-angled side edges to allow flush fitting joints between units, eliminating gaps and possible dirt traps.
- Pan supports in stainless steel.
- Unit is 900mm deep to give a larger working surface area.

APPROVAL: \_\_\_\_\_

### Included Accessories

- 1 of GN2/1 chrome grid for static oven PNC 164250

### Optional Accessories

- GN2/1 chrome grid for static oven PNC 164250
- Junction sealing kit PNC 206086
- Draught diverter, 150 mm diameter PNC 206132
- Matching ring for flue condenser, 150 mm diameter PNC 206133
- 4 wheels, 2 swivelling with brake (EVO700/900). It is mandatory to install with base supports for feet/wheels. PNC 206135
- Flanged feet kit PNC 206136
- Frontal kicking strip for concrete installation, 800 mm PNC 206148
- Frontal kicking strip for concrete installation, 1000 mm PNC 206150
- Frontal kicking strip for concrete installation, 1200 mm PNC 206151
- Frontal kicking strip for concrete installation, 1600 mm PNC 206152
- Pair of side kicking strips for concrete installation PNC 206157
- Side handrail for right/left hand PNC 206165
- Frontal handrail 800 mm PNC 206167
- Single burner radiant plate for pan support PNC 206170
- Single burner smooth plate for direct cooking - fits frontal burners only PNC 206171
- Single burner ribbed plate for direct cooking - fits frontal burners only PNC 206172
- Frontal kicking strip, 800 mm PNC 206176
- Frontal kicking strip, 1000 mm PNC 206177
- Frontal kicking strip, 1200 mm PNC 206178
- Frontal kicking strip, 1600 mm PNC 206179
- Pair of side kicking strips PNC 206180
- 2 panels for service duct (single installation) PNC 206181
- Large handrail (portioning shelf) 800 mm PNC 206186
- Frontal handrail 1200 mm PNC 206191
- Frontal handrail 1600 mm PNC 206192
- 2 panels for service duct (back to back installation) PNC 206202
- Pair of cast iron grids for gas ranges and boiling tops PNC 206208
- 4 feet for concrete installation (not for 900 line freestanding grill) PNC 206210
- Flue condenser for 1 module, 150 mm diameter PNC 206246
- Water column with swivel arm (water column extension not included) PNC 206289
- Water column extension PNC 206290
- Stainless steel grid for 2 burners PNC 206298

- Chimney upstand, 800 mm PNC 206304
- 2 side covering panels, height 700 mm, depth 900 mm PNC 206335
- Wok pan support for open burners (EVO700/900) PNC 206363
- Base support for feet or wheels - 800mm (EVO700/900) PNC 206367
- Base support for feet or wheels - 1200mm (EVO700/EVO900) PNC 206368
- Base support for feet or wheels - 1600mm (EVO700/900) PNC 206369
- Base support for feet or wheels - 2000mm (EVO700/900) PNC 206370
- Rear paneling - 800mm (EVO700/900) PNC 206374
- Rear paneling - 1000mm (EVO700/900) PNC 206375
- Rear paneling - 1200mm (EVO700/900) PNC 206376
- Kit town gas nozzles (G150) for EVO900 gas ranges on gas oven PNC 206385
- Chimney grid net, 400mm PNC 206400
- Kit G.25.3 (NI) gas nozzles for 900 freestanding gas cookers on oven PNC 206458
- Pressure regulator for gas units PNC 927225

**Front**

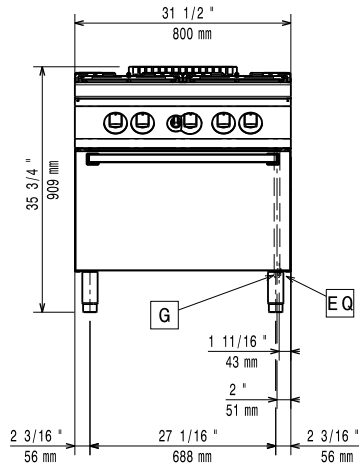

**Side**

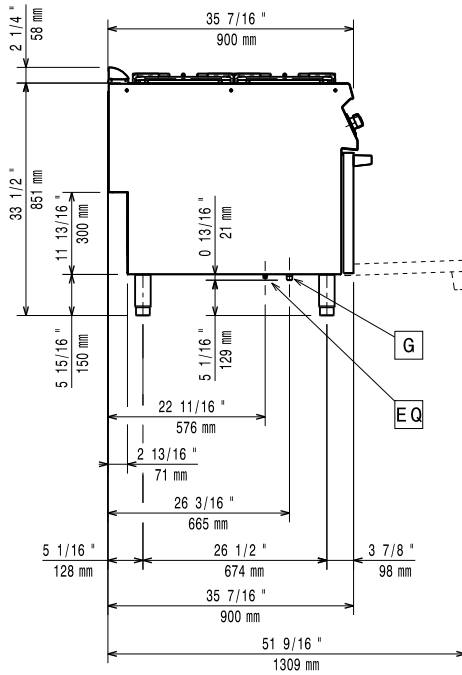

G = Gas connection

**Top**

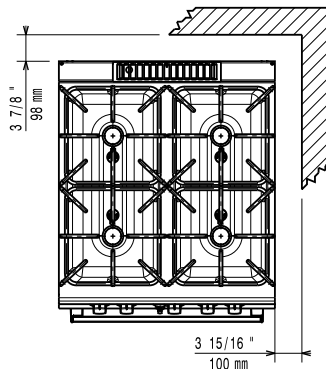

**Gas**

**Gas Power:**

392004 (Z9GCGH4SGL)

32.5 kW

**Standard gas delivery:**

Natural Gas G20 (20mbar)

**Gas Type Option:**

LPG; Natural Gas

**Gas Inlet:**

1/2"

**Key Information:**

<b>Front Burners Power:</b>	6 - 6 kW
<b>Back Burners Power:</b>	6 - 6 kW
<b>Back Burners Dimension - mm</b>	Ø 60 Ø 60
<b>Front Burners Dimension - mm</b>	Ø 60 Ø 60
<b>Oven working Temperature:</b>	120 °C MIN; 280 °C MAX
<b>Oven Cavity Dimensions (width):</b>	575 mm
<b>Oven Cavity Dimensions (height):</b>	300 mm
<b>Oven Cavity Dimensions (depth):</b>	700 mm
<b>Net weight:</b>	155 kg
<b>Shipping weight:</b>	120 kg
<b>Shipping height:</b>	1080 mm
<b>Shipping width:</b>	1020 mm
<b>Shipping depth:</b>	860 mm
<b>Shipping volume:</b>	0.95 m <sup>3</sup>
<b>Certification group:</b>	N9CG

If appliance is set up or next to or against temperature sensitive furniture or similar, a safety gap of approximately 150 mm should be maintained or some form of heat insulation fitted.